

For nominal dia. 250 to 400

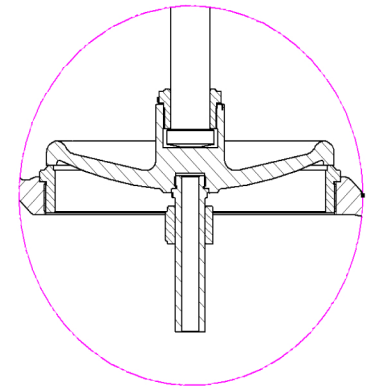
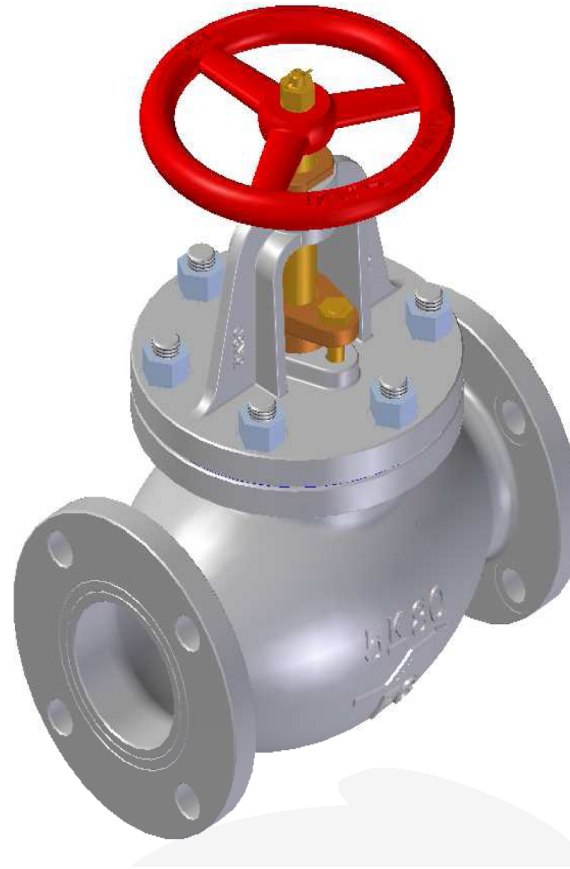
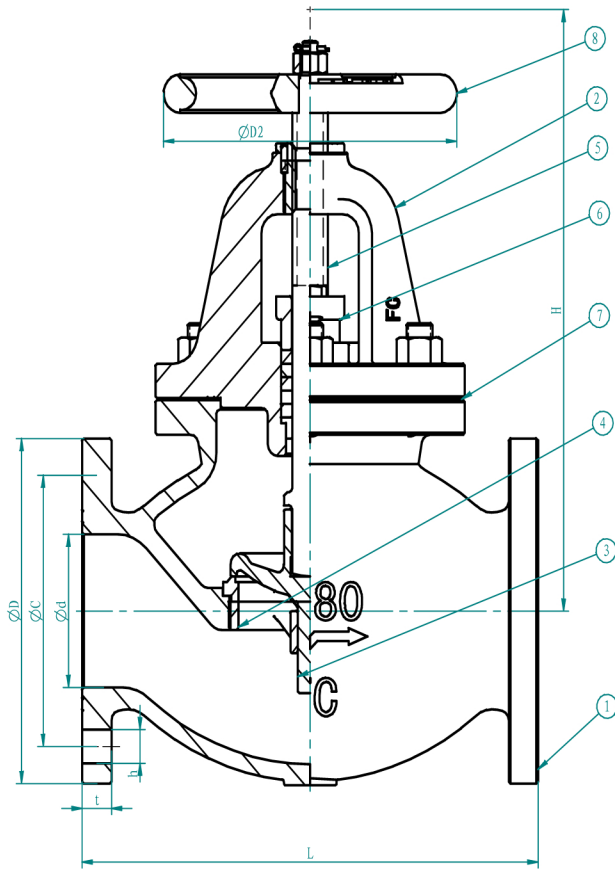

DESIGN STANDARD/设计标准		JIS F 7353-1996	
TEST/检验		JIS F 7400-1996	
HYDRAULIC INSPECTION/压力试验			
TEST PRESSURE / 试验压力	Mpa	DODY / 强度	300 OR LESS 1.05
			350, 400 0.9
		SEAT / 密封	300 OR LESS 0.77-0.4
			350, 400 0.66-0.3

适用于淡水、空气或其他气体、油以及温度不高于205℃的蒸汽等介质的船舶管路系统

DN	d	L	D	C	NO.	h	t	H	D2
50	50	210	130	105	4	15	16	270	160
65	65	250	155	130	4	15	18	290	180
80	80	280	180	145	4	19	18	300	180
100	100	340	200	165	8	19	20	350	224
125	125	410	235	200	8	19	20	380	250
150	150	480	265	230	8	19	22	430	280
200	200	570	320	280	8	23	24	505	315
250	250	740	385	345	12	23	26	620	355
300	300	840	430	390	12	23	28	715	400
350	335	940	480	435	12	25	30	815	500
400	380	1050	540	495	16	25	30	905	560

序号	零件名称	CLASS B	CLASS S	NAME OF PART	CLASS B	CLASS S
8	手轮	HT200		HANDWHEEL	FC200	
7	垫片	非石棉		GASKET		
6	压盖	ZCuSn5Pb5Zn5		packing gland	BC6	
5	阀杆	HPb59-1	1Cr12	STEM	C3771BD OR BE	SUS 403
4	阀座	ZCuSn5Pb5Zn5	ZG2Cr13	VALVE SEAT	BC6	SCS2
3	阀盘	ZCuSn5Pb5Zn5	ZG2Cr13	DISC	BC6	SCS2
2	阀盖	HT200		BONNET	FC200	
1	阀体	HT200		BODY	FC200	
		CLASS B	CLASS S	NAME OF PART	CLASS B	CLASS S
		材料			MATERIAL	
铸铁球阀截止回阀 5K				Cast iron 5K screw-down check valves		