

For nominal dia. 250

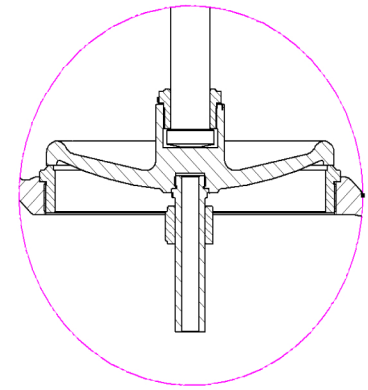

DESIGN STANDARD/设计标准	JIS F 7375-1996	
TEST/检验	JIS F 7400-1996	
HYDRAULIC INSPECTION/压力试验		
TEST PRESSURE / 试验压力 Mpa	DODY / 强度	2.1
	SEAT / 密封	1.54-0.4
适用于淡水、空气或其他气体、油以及温度不高于205℃的蒸汽等介质的船舶管路系统		

DN	d	L	D	C	NO.	h	t	H	D2
50	50	220	155	120	4	19	20	285	160
65	65	270	175	140	4	19	22	305	200
80	80	300	185	150	8	19	22	315	200
100	100	350	210	175	8	19	24	360	250
125	125	420	250	210	8	23	24	410	280
150	150	490	280	240	8	23	26	455	315
200	200	570	330	290	12	23	26	530	355
250	250	740	400	355	12	25	30	645	450

序号	零件名称	材料		NAME OF PART	MATERIAL	
		CLASS B	CLASS S		CLASS B	CLASS S
8	手轮	HT200		HANDWHEEL	FC200	
7	垫片	非石棉		GASKET		
6	压盖	ZCuSn5Pb5Zn5		packing gland	BC6	
5	阀杆	HPb59-1	1Cr12	STEM	C3771BD OR BE	SUS 403
4	阀座	ZCuSn5Pb5Zn5	ZG2Cr13	VALVE SEAT	BC6	SCS2
3	阀盘	ZCuSn5Pb5Zn5	ZG2Cr13	DISC	BC6	SCS2
2	阀盖	HT200		BONNET	FC200	
1	阀体	HT200		BODY	FC200	
		CLASS B	CLASS S	NAME OF PART	CLASS B	CLASS S
		材料			MATERIAL	
铸铁球形截止止回阀 10K				Cast iron 10K screw-down check valves		